



Sika·Design®



About Sika-Design



We are a Danish 3rd generation company founded in 1942, and specialize in quality interior and exterior woven furniture.

We are the worlds leading manufacturer of high end natural rattan furniture and we have our own factory in Indonesia.

With furniture from Sika-Design you can create a contemporary or classical exterior space with our luxury synthetic rattan exterior furniture.

Sika-Design interior rattan furniture allows you to create an interior space with lightweight but very strong furniture.

Our collections are designed to live long. Whether it is our contemporary or more classical furniture collections, you are guaranteed continuity and stability.

Our history – since 1942

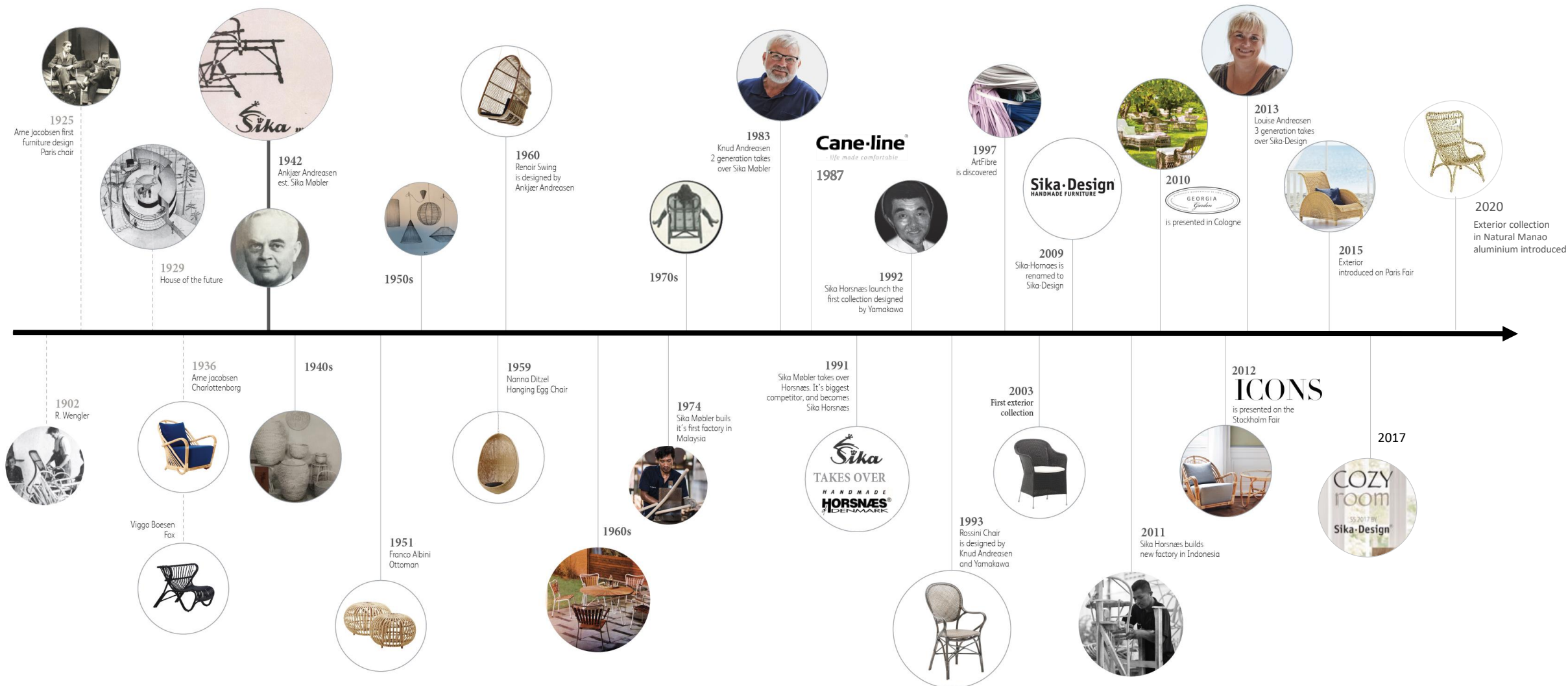

Why us?

INTERIOR & EXTERIOR FURNITURE

- Excellent customer service
- Beautiful designs and outstanding quality
- Designs by world famous architects like **Arne Jacobsen, Nanna Ditzel & Franco Albini**
- Competitive pricing
- On time delivery
- All products are made in Indonesia in our own factory
- Handmade cushions from our own production in Denmark
- 2 year full warranty
- Big warehouse with a lot of stock in Denmark for quick delivery
- You can mix orders across all collections from warehouse Denmark
- We have a home accessories collection called ATMOSPHERE to complete the decor
- No minimum order quantity from warehouse Denmark
- All items available as 3D drawing to visualize your project
- We also offer direct containers from Indonesia based on FOB terms

Our catalogues!

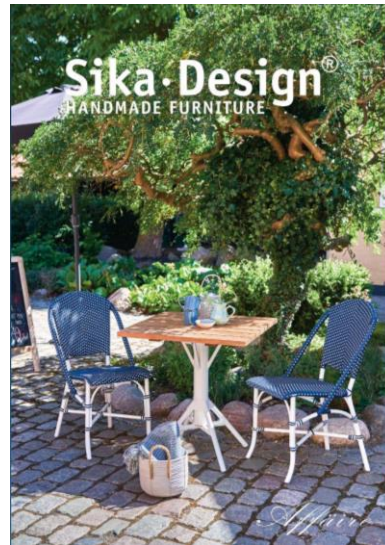

Sika-Design®
HANDMADE FURNITURE

Our Architects

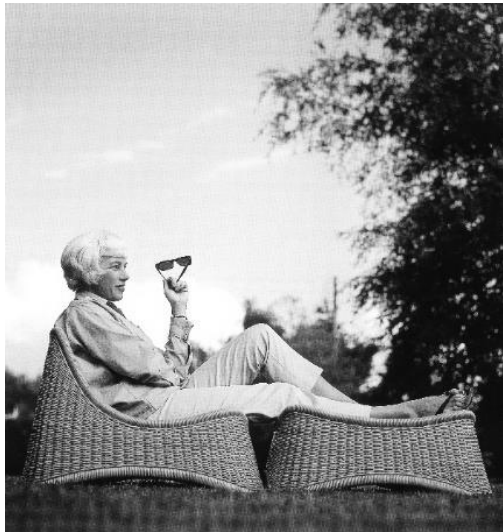

Viggo Boesen



We are specialists in rattan furniture and we aim to become the market leader and number one brand in the world of rattan furniture.

The Sika deer – our logo from the 1950's

1950's



2017



Sika·Design[®]
HANDMADE FURNITURE



Sika·Design[®]



Office, warehouse and showroom in Denmark



Office, warehouse and showroom in Denmark

In Denmark we have our office, warehouse and showroom.

Our Showroom
is: 470 m²

Our warehouse
is: 11.000n m²

We always encourage our customers and partners to come and visit us.

We share our office building and warehouse with our sister company Cane-line, which was founded by Knud Andreasen in 1982.



Denmark – easy to visit us

We are based in Denmark, on the island called “Fyn” close to the city Odense which is where the famous poet H.C. Andersen was born.

From our head office and central warehouse in Denmark we mainly distribute to Europe.

We also distribute to the rest of the world out of Denmark.

It is easy to visit us. There is a direct train from Copenhagen airport and it only takes 1 hour and 15 minutes from Copenhagen to us.

We always encourage our customers and partners to come and visit us.



Our factory in Indonesia



Our factory in Indonesia is called SILCANE, and is located on Java, in the city called Cirebon.



Our materials



LLOYD LOOM

Loom is the name of a unique woven material, which consists of a twisted Kraft paper that is partly reinforced with steel wire. It is smooth to the touch, with no sharp joints in the weave, it does not bend, distort or creak when used and it is remarkably strong and durable. The frames of all our Loom products are made in natural rattan.



TEMPOTEST[®] FABRICS

Our Italian Tempotest[®] fabrics are treated with a special type of finishing. During the treatment process, the finish is deposited not only on the surface of the fabric, but envelopes each individual fibre, forming an impenetrable barrier without compromising the fabric's breathability. The HI-Clean finishing makes Tempotest[®] fabrics water and oil repellent, proof against rotting and immune to the formation of mould and fungus.



OUICKDRYFOAM[®]

Urecel QuickDry is advanced high-performance foam designed specifically for outdoor cushions. The large, open pores in Urecel QuickDry allow water to drain very rapidly and fresh air to circulate freely and continuously. This foam is the perfect seating solution for places with regular rainfall and high humidity.



GLASS TOPS

All our glass tops, which are made from 8 mm tempered glass is easy to clean and more durable than ordinary glass. Handle with care! A damaged edge or scratched surface can in exceptional cases cause the glass to crack suddenly. However, never into sharp fragments, only into small pieces. Avoid collisions from the side - this is where the glass is most vulnerable. MAINTENANCE: Wash with water mixed with mild soap and remove stains with a sponge or medium brush.



MATERIALS & MAINTENANCE

NATURAL RATTAN

Rattan is a natural climbing plant that grows in the Indonesian rainforest. Rattan grows naturally without disturbing the existing structure and balance in the rainforest. Rattan is strong, lightweight, flexible and durable. MAINTENANCE: Wash with water mixed with mild soap and remove stains with a sponge or medium brush.



TEAK TABLES & TOPS

Only premium sustainable plantation-grown teak from Indonesia is used for the manufacture of our teak tables. All teak wood sourcing is overseen by the Indonesian government, which means that no healthy tree too immature, or too small is removed from the forest. MAINTENANCE: Wash with water mixed with mild soap using a sponge or medium brush. If you wish to treat your teak furniture, use teak oil - notice that this will make the wood darker.



ARTFIBRE[®]

Sika-Design ArtFibre[®] is a fibre made of dyed and hard-wearing polyethylene. It is ideal for outdoor use in any climate as it is temperature and UV-resistant. The ArtFibre[®] is flexible and, when woven, provides optimal comfort and a structure that is strong and can maintain its shape for years on end. MAINTENANCE: Wash with water mixed with mild soap and remove stains with a sponge or medium brush.



ALU RATTAN[®]

All our aluminium furniture is powder coated. The powder coating ensures a surface resistant to knocks and scratches. The furniture is well-suited to be left outside all year long and is easy to clean. MAINTENANCE: Wash with water mixed with mild soap and remove stains with a sponge or medium brush.



VERSALITE TOPS

Our artificial contract table tops are easy to maintain because of its smooth, scratch free and hygienic surface. These artificial tops are strong and stable and they are resistant to all weather conditions. These tops are the perfect choice for restaurants and hotels. MAINTENANCE: Wash with water mixed with mild soap and remove stains with a sponge or medium brush.



AVANTGARDE[®] STEEL

Our Avantgarde collection is very unique due to the fact that the frame is made of steel. The steel is specially treated and welded to last for decades. This unique treatment enables the furniture to stand outside all year long enduring all elements of nature. MAINTENANCE: Wash with water mixed with mild soap and remove stains with a medium brush, or use pressure washing.

Read more about this in our catalogues or on our website:
www.sika-design.com

Exterior cushions



QuickDry foam is the advanced high performance foam designed specifically for Outdoor cushions. The large open pores in QuickDry allow water to drain very rapidly and fresh air to circulate freely and continuously – to ensure a fast drying process.

QuickDry is the perfect seating solution for customers in climates with regular rainfall and high humidity.

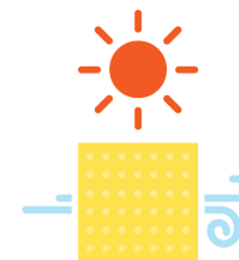

What is rattan?



Hugging the trees

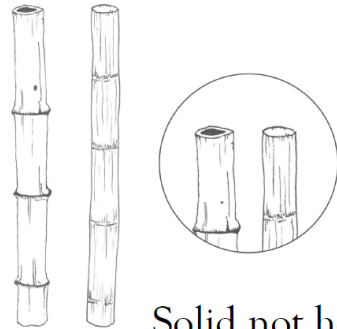

Solid not hollow

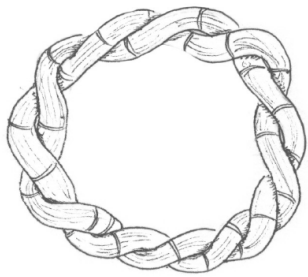

Full circle

RATTAN IS A GENEROUS PLANT

Rattan is a climbing palm that grows as a vine in the rainforest. The vines creep up the trees from the bottom of forest and have been known to grow up to hundreds of metres long. Rattan grows naturally without disturbing the existing structure and balance in the rainforest while at the same time cleaning the air by transforming CO₂ into clean air.

RATTAN IS IMPOSSIBLE TO WEAR OUT

There is a common misconception that rattan furniture is made of bamboo. There is quite a big difference between rattan and bamboo although they look similar on the surface. Rattan stems are solid whereas bamboo stems are hollow. This means that if the material is bent into shape, it is rattan. Unlike bamboo, rattan furniture is extremely hardwearing and can last for generations.

RATTAN IS A SUSTAINABLE WOOD

As rattan grows by climbing the trees in the rainforest, it is important to preserve the trees in order to preserve the rattan production. This means that rattan indirectly helps to preserve the rainforest in Indonesia. It is the fastest growing tropical wood and it regenerates in 5-7 years. The production of the furniture is low tech and does not require production facilities that pollute the environment.

RATTAN CAN BE USED IN MANY WAYS

Rattan can handle both high and low temperatures as well humidity and fluctuations in temperature. This means that the furniture can be used for many different situations. When rattan is processed, the cane is debarked and sanded down for a nice smooth surface that can be kept in the natural light yellow state or be stained and lacquered in different colours. The bark can also be left on for a more rustic look and feel.

RATTAN HARDLY REQUIRES ANY MAINTENANCE

Rattan does not need any special attention. For daily cleaning it can be wiped with a cloth or brush. For a more extensive cleaning, the furniture can be wiped with a wrung out dampened cloth with mild soap. If the furniture loses its shine over the years, it can be wiped with plain furniture oil.

Sustainability & circular economy



SUSTAINABILITY IS A VALUE CLOSELY WOVEN INTO SIKA-DESIGNS HISTORY

As one of the world's oldest and biggest producer of rattan furniture, sustainability has always been a part of Sika-Designs DNA. Since 1942, rattan has been key to sustainable furniture production. At Sika-Design we are delighted of the growing green awareness and the revival, which rattan is experi-

encing in these years. Not only in the light of the UN's sustainable development goals, which we actively are supporting.
Lean back and take with us on a tour in the world of rattan furniture.



RATTAN HUGS THE RAINFOREST

IMPORTANT TO KNOW ABOUT RATTAN

- Rattan is the second fastest growing material for furniture production and regenerates in the span of 5 to 7 years.
- Rattan contributes to save the rainforest, since the plant grows like vines on the trees.
- Rattan turns CO₂ into clear air and produces up to 35 % more oxygen than a tree.
- Opposite to bamboos is rattan not hollow, but solid. It is strong, bendable and very durable. It is perfect for furniture production.
- Rattan is nearly impossible to wear out and lasts for many generations.
- Most (80 %) of the world's rattan resources grow in Indonesia, close to Sika-Designs factories.
- Rattan is easy and environmental friendly to work with. The Rattan stem only needs to be steamed for 10-15 min, before it can be formed.
- All furniture from Sika-Design is woven and formed by hand using only a few machines in the process.
- Glue is not necessary in the production and Sika-Design only uses toxin free varnishes.
- Rattan comes in 600 different variants, whereof 40 can be used in the furniture production. Sika-Design only uses the best quality rattan: Tohiti and Manau.



SUSTAINABILITY AT THE HIGHEST LEVEL

When you sit down, slouch yourself or put lie down in a piece of furniture from Sika-Design, it can carry in more than one way. Not only is it comfortable, but our furniture is made from some of nature's most environmentally friendly material.

According to the Indonesians, rattan hugs the rainforest. It can be understood quite literally, and at the same time articulates the truth that the profitable grass species helps preserve the rainforest. The rattan cleans the air and converts CO₂ into clean air.

A TRADITION-BOUND CRAFT
Sika-Designs factories are located in Indonesia, where the wickerwork is a tradition-bound craftsmanship which is passed down from generation to generation. The harvest is done by hand and only a few machines are used in the production. The rattan stems only need to be steamed for 10-15 min, before it can be formed and woven by the skilful weavers.

TRANSPORTATION BY SHIP
We put a lot of effort into our value chain, so that our furniture - both under the production, transportation and at your home - affects the environment as little as possible. We ship our products with ship directly from our factories to large exporting markets such as Australia, South Africa, South America and the US. Therefore, the furniture does not go to Denmark before being shipped out in the world, and thus reduces the shipping period. Many of our products are stackable and all these things are part of our mission to reduce our carbon footprint.

At Sika-Design we value the original craftsmanship, which combines proud weaving traditions with a sustainable and modern production, where social responsibility is valued high. We are certified with the international ISO14001 and SA8000 standards and all production complies with the local law (Indonesian Legal Wood).

3



THIS IS HOW SIKA-DESIGN WORKS WITH THE UN'S WORLD



At Sika-Design, we constantly optimize the processes in a sustainable direction through a general focus on responsible usage and production, which aligns with UN's World Goal no. 12. This is where we can make a change.

Since Sika-Design was founded in 1942, sustainability has been a natural and integrated part of our mindset. Throughout the years, we have developed a systematical and focused effort to ensure as little as possible strain on the environment through the optimization of production processes and sustainable logistics, transportation and distribution.

For a furniture manufacturer as Sika-Design is sustainability a three-legged chair, which stands on a social, environmental friendly and economic leg.

We have a continuous focus on all three parameters. As a furniture manufacturer we actively support UN's World Goals, especially no. 12, where we can make a change. When there is a natural connection between Sika-Designs core values and business, we wish to take a proactive initiative to protect our employees, society and the environment, both locally and globally.

"When I started in the furniture business many years ago, I was intrigued by the rattan material's design possibilities. This fascination has only become even greater in our ongoing awareness of the material's exceptional sustainability".

LOUISE ANDREASEN
3rd generation,
Sika-Design



**ENSURE SUSTAINABLE CONSUMPTION
AND PRODUCTION PATTERNS**

Read more about this in our catalogues or on our website:

<https://sika-design.com/pages/sustainability>

Sustainability & circular economy

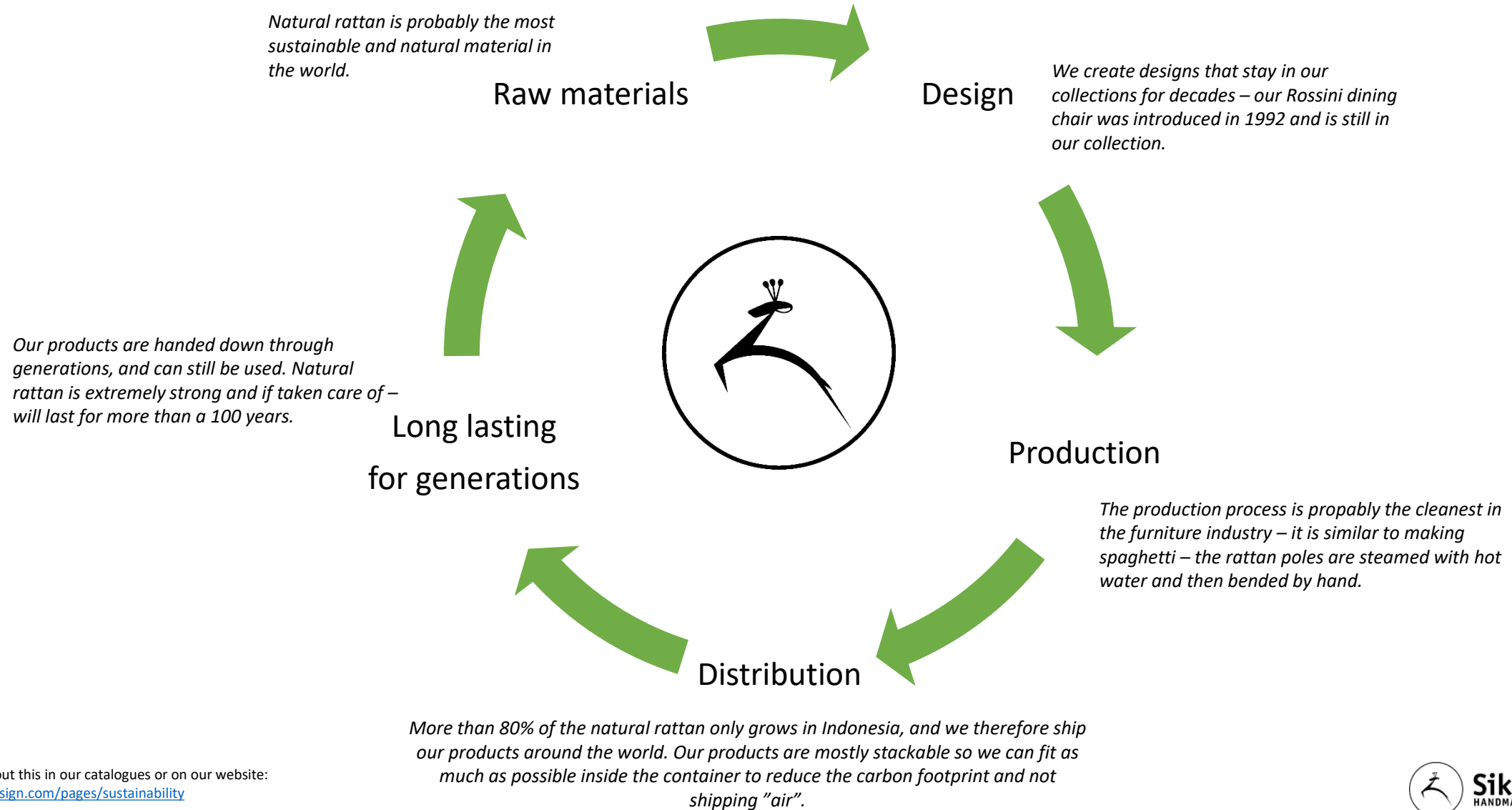

Social responsibility and environment



Environment and social accountability policy

Sika-Design strives to supply sustainable and comfortable quality furniture manufactured with respect for the environment and social accountability.

We attempt to improve our efforts on behalf of the environment on an ongoing basis and comply with ISO14001. We take responsibility for the people who create our furniture. We aim to minimize the consumption of resources and prevent pollution in our supply chain.

Sika-Design does not accept child labor, respect human rights and complies with the SA8000 standard for social accountability, and we demand the same commitment from our suppliers.

We focus on design and comfort and also take the environment into account when we choose our raw materials and develop new production methods and products.

Sika-Design complies with environmental and labour legislation and demand that our suppliers comply with their legislations within these areas.



Our fabrics and cushions

FABRICS AND CUSHIONS

The quality of good craftsmanship is also felt in our cushions, where we draw on great experience and expertise when we decide the shape and characteristics of each cushion. Our high-quality upholstery and seat cushions are made to order and can be chosen from a broad variety of high quality fabrics and styles. You can also send us your own selection of fabrics, and we will make cushions in your own fabrics.

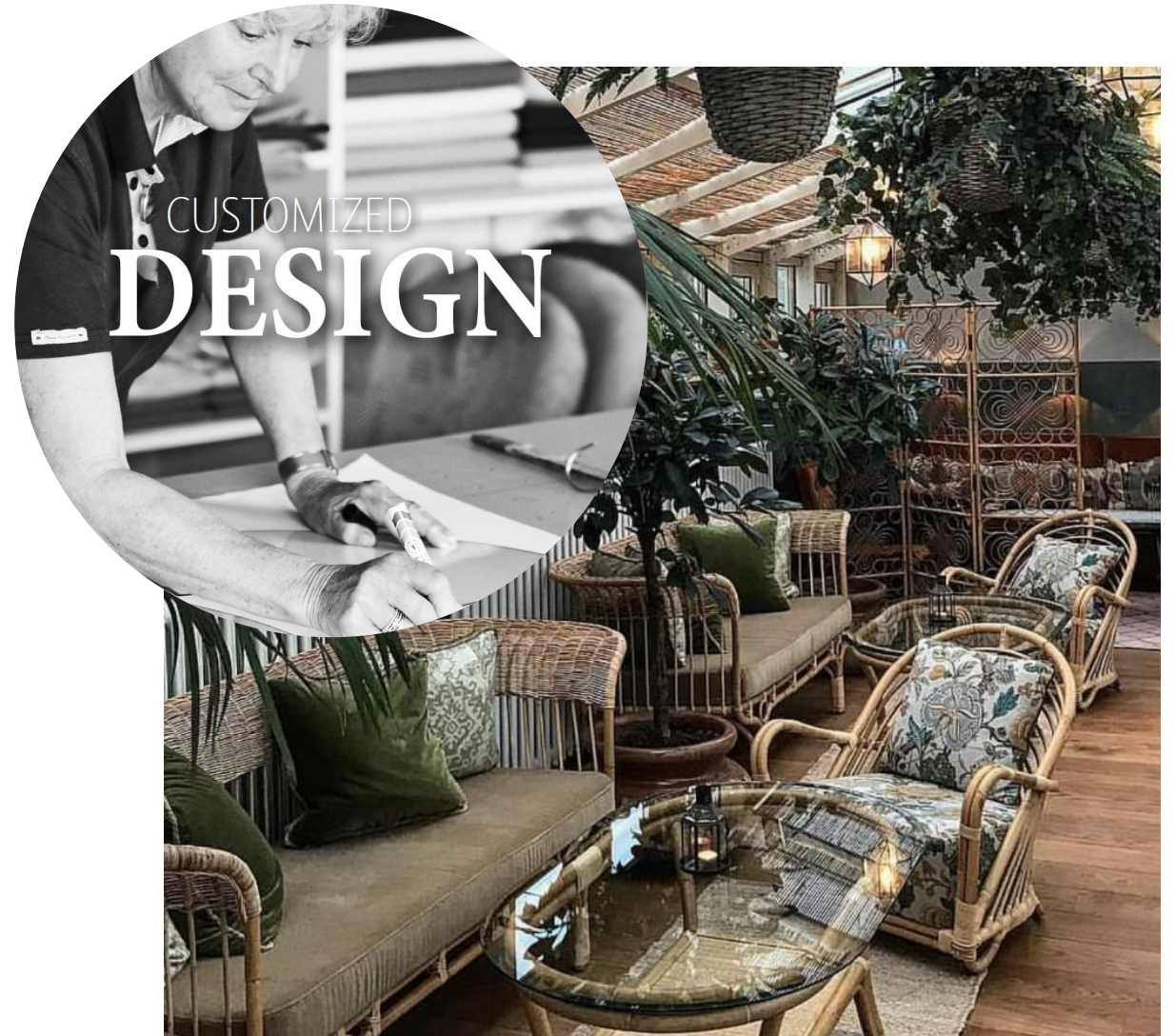

Sika-Design & Contract business

STACKABLE & COMFORTABLE

Several of our chairs are stackable, making them easy to store away after a busy day, getting ready for closing time at the café. The Danish minimalist design is suitable everywhere. The structure of the ArtFibre and the woven seats provide flexibility and optimum comfort.

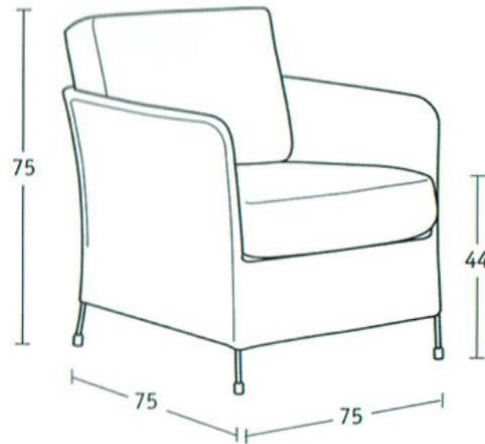

FINE CRAFTSMANSHIP & MODERN TECHNOLOGY

Sika-Design selects its materials very carefully. Sika-Design work with finest quality of natural rattan and the newest technology in aluminum – also called AluRattan. We have the best craftsmen working with us in our factory. Our furniture is designed to withstand everything nature can throw at it – rain, snow and UV-rays from the sun.

Sika-Design & Contract cases – a selection



Become a Sika-Design partner

FULL CONTACT DETAILS

It is very easy to become a Sika-Design partner – just send us an e-mail with the below details:

- / **Company name:**
- / **Company address:**
- / **VAT number:**
(If within EU)
- / **Country code:**
- / **Phone number:**
- / **Contact person name:**
- / **Contact person e-mail:**
- / **Delivery address:**
(If different from company address)

The screenshot displays the Sika-Design website's Store Locator interface. At the top, there is a navigation menu, the Sika-Design logo, and a search bar containing the text "What are you looking for?". Below the search bar, the text "Store Locator" is visible. A search input field contains the text "fyn", followed by a "SEARCH" button. The search results are listed on the left side of the page, showing two store locations:

- Central Møbler, Odense A/S** (7.3 km): Magnoliavej 3-5, Odense SV, DK-5250. Phone: 66 17 54 36. Email: info@centralmoebler.dk.
- Frk. Dusa ApS** (9.7 km): Dalumvej 59, Odense SV, DK-5250.

To the right of the search results is a map of the region, showing various municipalities and towns. The map includes a "Map" and "Satellite" view selector, a search bar, and a "CART" icon. A mail icon is also visible in the bottom right corner of the map area.

Always inform us whether you are a furniture dealer/showroom, an interior designer or an architect.

B2B Webshop for professionals

PLACE ORDERS ON-LINE 24/7 – WHENEVER YOU WANT – WHEREEVER YOU ARE

On our website you can apply for user and get your own log-in to our B2B webshop, where you can **place orders** directly in our system, see **stock availability** in real time and see **prices** whenever you want..

Rynkebyvej 245 - Rynkeby, Denmark | Tel: +45 66 15 42 24

[Apply for Business Account](#)

[Contract & Hospitality](#)

[Partner Login](#)

Sika·Design®
HANDMADE FURNITURE

What are you looking for?



[HOME](#)

[PRODUCTS](#) ▾

[COLLECTIONS](#) ▾

[DESIGNERS](#) ▾

[DISCOVER](#) ▾

[STORE LOCATOR](#)



 **Sika·Design®**
HANDMADE FURNITURE

How to use our digital platform

ALL INFORMATION YOU NEED IS ON-LINE

On our website we have all the information you need, and it is easy to access as we do not have any password.

Go to the menu in the top bar called “**Downloads**” here you can find:

/ IMAGES IN HIGH RESOLUTION

/ 3D FILES

/ FACT SHEETS

/ FABRIC & COLOUR SAMPLES

/ ELECTRONICAL CATALOGUES

/ COLOUR & MATERIAL SAMPLES

Sika·Design[®]
HANDMADE FURNITURE

Products

Fabric collection

Designers

About Sika-Design

Events

Retailers

Be inspired

Scrapbook

Downloads



Private label



Fairs around the world

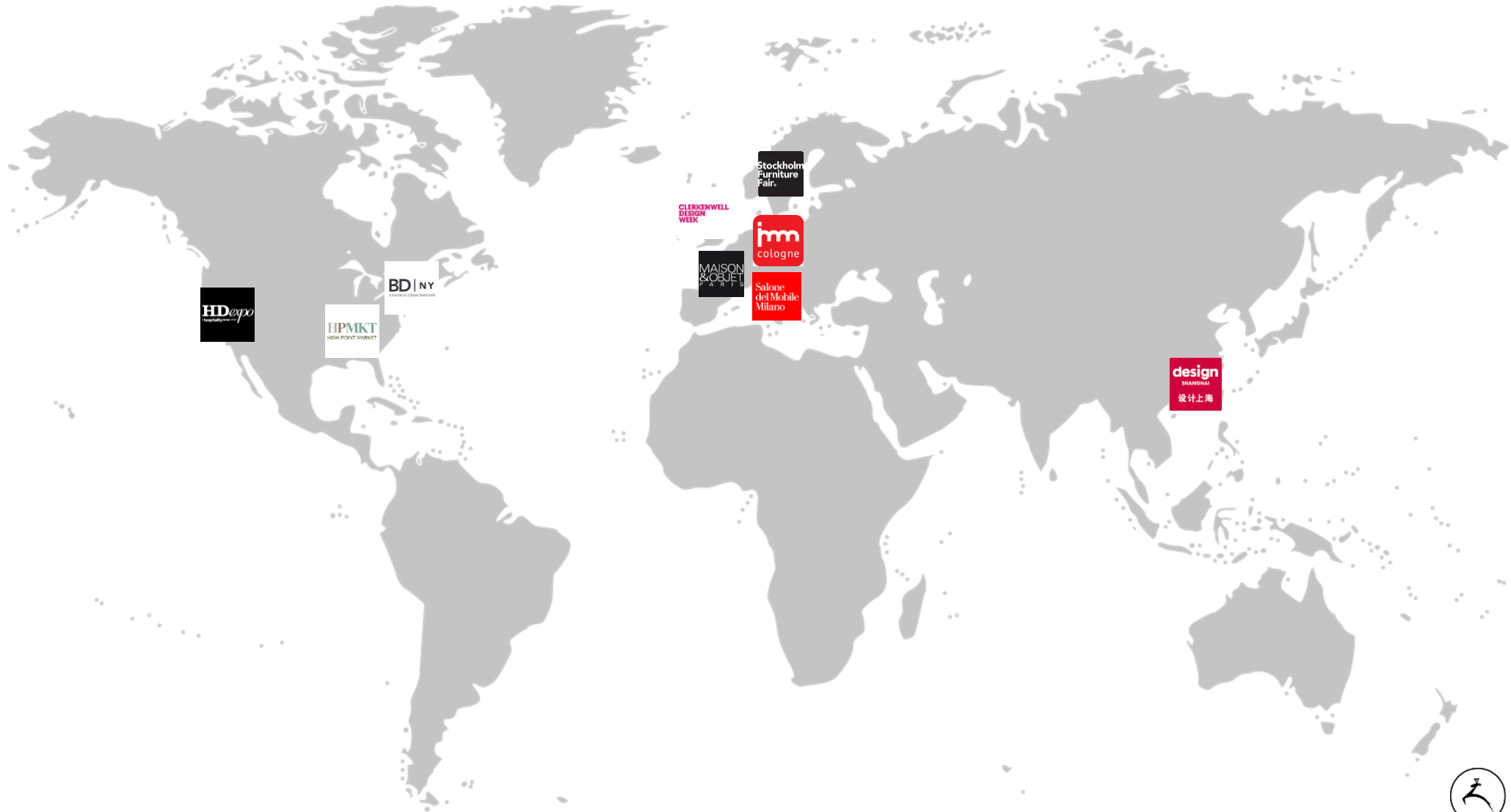

Social media – follow us!

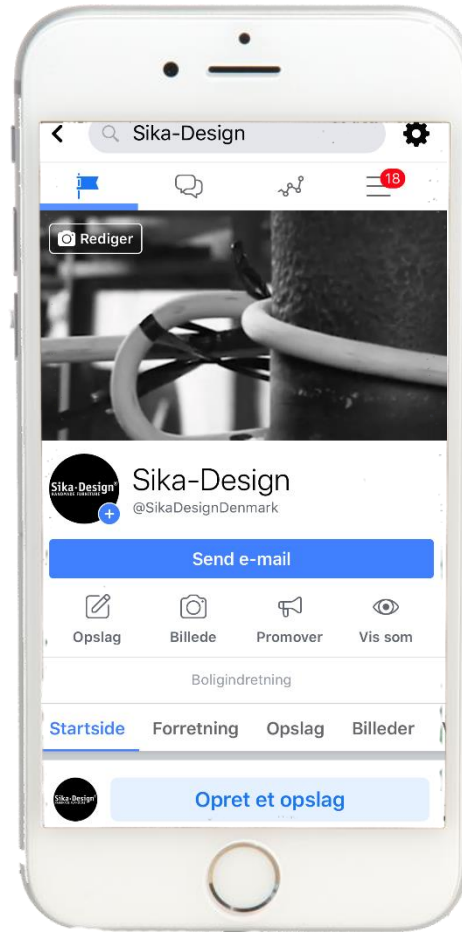
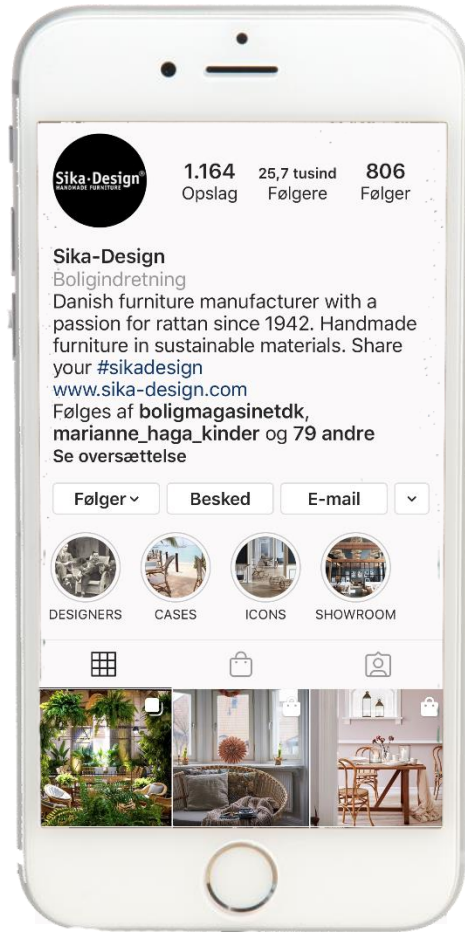

GET INSPIRED

Sika-Design always show our latest products, projects and events on social media.

Our social media is a way to find inspiration and also follow what we and our partners do around the world.

So don't hesitate to follow us on Instagram, facebook, LinkedIn or pinterest.

Thank you for your attention



If you have any questions or you would like further information, catalogues, pricelists or a quote please contact us by e-mail.

We generally have everything in stock and we can deliver and have shipments ready in 2-3 weeks.

Contact us at info@sika-design.com

Thank you!

Sika-Design A/S



Sika-Design®